

WSN-Based Smart Sensors and Actuator for Power Management in Intelligent Buildings

Pochampelli Sai Prasad(178r1a0446), Sungala Rukesh(178r1a0451), Tushar Goel(178r1a0453),
Vilasagaram Kiranmayee(178r1a0457)

Department of ECE, C M R Engineering college, Hyderabad, Telangana, INDIA

Abstract- In this paper we have reported the system for design as well as development of a smart monitoring And controlling system for household electrical appliances in real-time. The system basically monitors electrical parameters of household appliances like voltage and current and subsequently calculates the power consumed by the system. The goodness of system is the implementation of the controlling mechanism of appliances in various ways. The developed system is of low-cost and very flexible in operation and thus can save electricity expense of the end consumers. The prototype has been extensively tested in real- life situations and experimental results are very good.

are being used rapidly like regular appliances used in housing hold are being monitored and controlled very efficiently.

The cutting –edge advancements of new technology of WSNs are sensing, metering transmission of data distribution of data and storage of electricity. Also it work for providing new

*Keywords—*Wireless sensor network (WSN);
Raspberry Pi (Rpi); Zigbee ; Embedded
Linux .Web Design; Power Management.

I. INTRODUCTION

IT is always seen that service and personal care wireless mechatronic systems is very essential at home in the near future and become very useful in assistive for the people who are elder and disable for their Health care. this system is consist of the various types of specially distributed wireless sensors but having limited data collection and data processing capability to monitor the environmental parameter.

Wireless sensing network (WSNs) have the ability to to monitor as well as control the situational information for various intelligent service so day by day the demand for wireless sensor networks(WSNs) goes on increasing. Also for the field like Industry military, environment, healthcare, agriculture WSNs can be applied for various important applications.

For energy controlling Service at home the WSNs

Information and flexibility to both consumers and providers of electricity. The Zigbee union, wireless communication platform is working on the examination of newly adopted

System by Japan for home wireless system implication by having an initiative with the developed Japan's Government. It will closely analyse upcoming ZigBee Internet Protocol (IP) specification and related things, and the IEEE 802.15.4g Standard to complete the aim of Japan to generate smart homes that can improve energy management and efficiency.

The expectation is that 65 million households will equip with smart Meters by 2015 in the United States for the efficient use of electricity, and it is a practical estimate of the

Size of the home energy management market. Several ways exist to interconnect various domestic Appliances with the help of wireless networks to monitor and control such an advanced system. The smart metering design is as per the specific requirement considering the smart meter systems relating with the geographical area and they are limited according to specific places.

Practically various kinds of testing are done in residential flats for the minimum power utilization by integrating the different information and communication technologies and very specially designed smart meter devices but still the individual monitoring and control of the devices are limited to houses specifically.

II. AUTOMATED POWER MANAGEMENT SYSTEM

A. Basic System

For data conversion we are using the MCP3008 as a data converter. The conversion of data from analog input from different type of sensors into

digital output which is fed to ARM11 which is further going to display on the designed webpage. The Microchip Technology Inc. MCP3004/3008 devices have successive approximation of 10-bit Analog to-Digital (A/D)

converters and also have the on-board sample and hold circuitry to perform the necessary operation. The MCP3004 is programmable to get the two pseudo-differential input pairs for four single-ended inputs. The MCP3008 is programmable to provide more than one i.e four pseudo-differential input pairs or eight Single-ended inputs. Differential Nonlinearity (DNL) and Integral Nonlinearity (INL) are specified at ± 1 LSB. Communication with the devices is done by using the using a simple serial interface which is compatible with the SPI protocol. The devices are capable to converts the data rate up to 200 kbps. The MCP3004/3008 devices is operational over a broad voltage range (2.7V - 5.5V). Low-current design allow the operation to typical standby currents of only 5 nA and typical active currents of 320 μ A. The MCP3004 is offered in 14-pin PDIP, 150 mil SOIC and TSSOP packages, while the MCP3008 is offered in 16- pin PDIP and SOIC packages.

The first generation product of Raspberry Pi chip supports up to 700 MHz by default configuration and also having the advantage of that it did not become get hot up to that extent that to need a heat sink or special cooling system to enhance the performance, yet to overclock the chip. The second generation Raspberry Pi runs at 900 MHz by default, and also does not become hot enough to need a heat sink or special cooling. Again over clocking may heat up the SoC more than usual.

Figure 1: Basic Block Diagram.

B. System Description

The objective of the system is to measure the electrical parameter of the particular system and control the use of electricity to save the electricity up to great extent thus using this system we can measure the electrical Parameters of household appliances. The important functions

Of the developed system is the ease of modelling, setup, and use. Electrical power consumption of various appliances in a house along with supply voltage and current is the key parameter, with respect to view of the customer. .Fig. 1 shows the functional description of the developed system to monitor electrical parameters and control appliances based on the

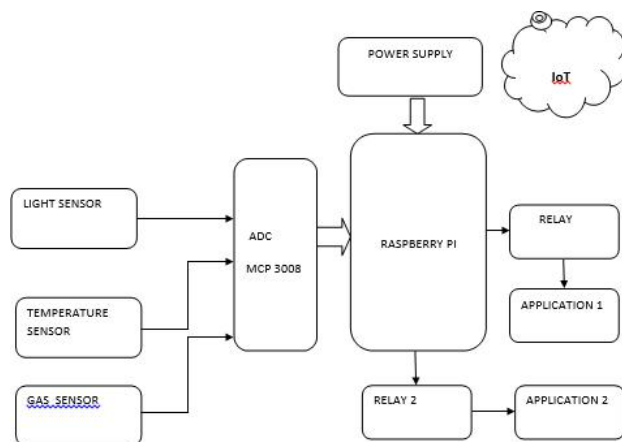

consumer requirements. The measurement of electrical parameters of home appliances with the help of different modules used in the system. Is done by the various interfaces of the fabricated sensing modules. The details of the design and development of the sensing modules is as per the below explain method. The output signals from the sensors are integrated and connected to XBee module the purpose of this is the transmission of electrical parameters data over wireless media.

The mesh topology is created to take advantages of the reliable data reception at a centralized ZigBee coordinator it is achieved by interfacing the The XBee modules with various sensing devices.. The maximum distance kept between the adjacent ZigBee nodes is less than 10 m, and through hopping technique of the mesh topology, and reliable sensor fusion data has been performed by hopping technique of the mesh topology created.

Through ZigBee protocol and also it processes the large quantity of data timely and available for users to view.

2) End device sensor node

The electrical parameters are sensed by Sensor node used here. It is designed using microcontroller board. It consists of the ZigBee based radio transceiver, power supply unit, moisture and electrical parameter sensor. Temperature sensors, and data logger for temporary storage. It senses the electrical parameter at one-minute intervals and will be send back to the coordinator node via the ZigBee protocol. The system monitoring and the control is depends on the values sense by the end sensor.

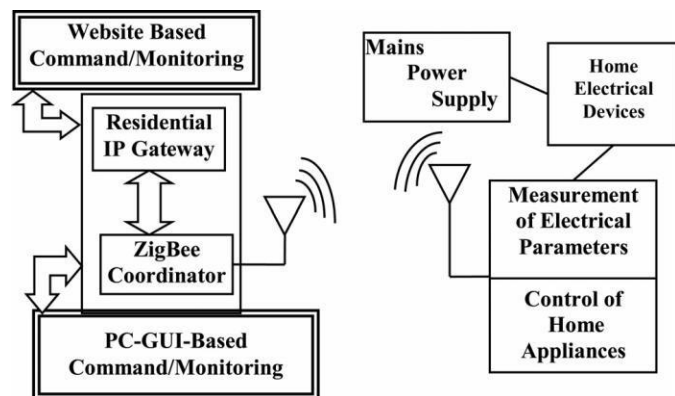

Figure 2: Architecture of System.

1) Raspberry Pi

Raspberry Pi is used as the controller of coordinator node in this proposed system as the use of Raspberry by is very efficient. The advantages of the Raspberry Pi is that it is is the small, cheap and a very good minicomputer.

The continuous collection of the information is done by the Rip to send the by Sensor nodes used in the system

3) ZigBee

The ZigBee is the protocol for wireless communication and which is based on the underlying protocol IEEE 802.15.4, controlling layer for media access and network physical layer is defined by it, while ZigBee defines the network layer, application layer and specifications of the network security services.

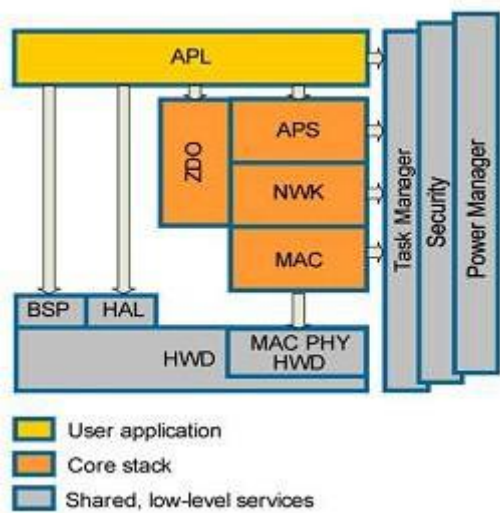

Figure. 3: IEEE 802.15.4 ZigBee stack standard.

ZigBee is described by referring to the 7-layers of the OSI model for layered communication systems. The Alliance specifies the bottom three layers Physical, Network, and Data link, as well as Application Programming Interface that allows end developers have the ability to design custom applications that use the services provided by the lower layers.

4) Database and web server

In this system we have designed the database based on MySQL which is installed on Rpi. For web application MySQL is popular choice of database i. MySQL is also termed as or refer as the relational database management system. And main feature is that It is open source software. Database stores the electrical parameter information sent by

sensor node for sensing the electrical parameter. And for monitoring the system it provides the information to the webpage

5) Sensors

a) Thermocouple:

It is a type of temperature sensor which is used to collect the field data, which is form by joining two dissimilar metals at one end. The sensor is as shown in fig-4 The joined end is referred to as the HOT JUNCTION. The other end of these dissimilar metals is called as the COLD END or COLD

JUNCTION. The cold junction is actually formed at the last point of thermocouple material. The small voltage is created only when there is the temperature difference between the hot junction and cold junction. This voltage is referred to as an EMF (electromotive force) and it can be measured and in turn used to indicate temperature.

Figure 4: Thermocouple

b) Thermistors:

Similar to the RTD there are some similar type of the sensor one of which is the thermistor it is a temperature sensing device whose resistance changes with temperature. Depending upon the values of the resistance it indicates the values of the electrical parameter on display Thermistors are made from semiconductor materials. Resistance is determined in the same manner as the RTD but there is change in their linearity characteristics, thermistors don't have a linear resistance vs. temperature curve. Thus, as convey early thermistors operating range we can see a large resistance change for a very small temperature change that is due to their non-linearity characteristics. So the sensitivity of the RTD is very high and it is that's why a highly sensitive device and ideal for set-point applications.

c) LM35 Temperature Sensor

Calibrated directly in ° Celsius

(Centigrade) Rated for full 1 – 55°

to +150°C range

Suitable for remote applications

Low cost due to wafer-level trimming

Operates from 4 to 30 volts Low self-heating,

d) *Introduction to Raspberry pi*

The Raspberry Pi has low cost credit size minicomputer which has now become popular with respect to his features.

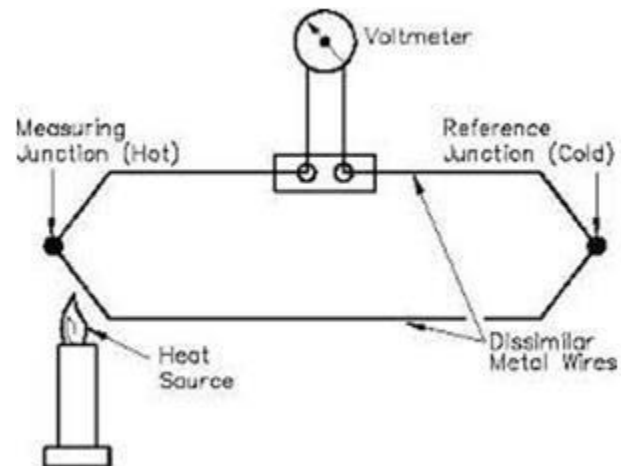

The Raspberry is the cheap low power arm 11 based microcontroller operating at 700MHz frequency and having the 512 megabytes (MB) of RAM memory. Fig.5. shows the picture of Raspberry Pi.

Features of the Raspberry Pi

- Raspberry Pi(Model B+) has Mounting Points and 512MB RAM.
- Integrated Video core 4 Graphics GPU capable of playing Full 1080p HD Video.
- 4 x USB Ports.
- Board Power Draw: 600mA.
- HDMI Video Output.
- 10/100Mb Ethernet Port for Internet.
- Flash Memory Card Slot (Micro SD).
- 40-pin 2.54mm Header Expansion Slot, Which allow for peripherals and expansion boards
- Dimensions 85 x 56 x 17mm.
- external memory card with rasbian wheezy images are used to boot The Raspberry Pi

computer system for further analysis and decision. Then we can get the data and collected sensor fusion data have been sent to an internet residential gateway for the purpose of the remote monitoring and controlling the home environment. By calculating and analysing the power from the system. Then we can decide the limit of energy consumption and energy consumption can be controlled. An electricity tariff plan has been set up to run various appliances at the varying level of peak first and then

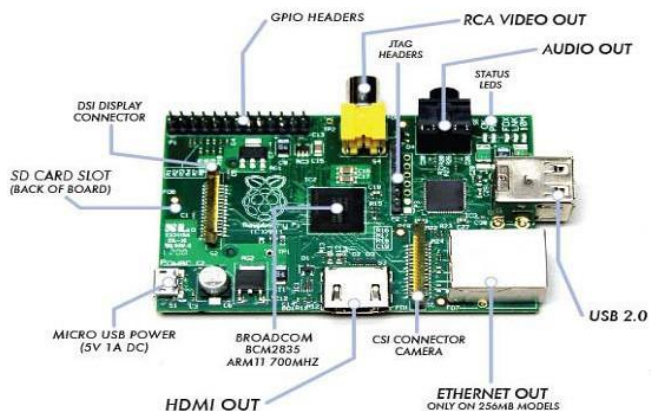

Figure 5: Raspberry Pi.

III. POWER MANAGEMENT OPERATION

For the connection between the ZigBee coordinator and host computer is interface with standard of the USB cable which stores the data into a database of

off-peak tariff rates to control the consumption. The appliances are controlled either automatically or manually depending upon the choice of the user (local/remotely). The smart power metering circuit is connected to mains 240 V/50 Hz supply. Fig. 2 shows different appliances connected to the developed smart sensing system

Figure 6: system flowchart

IV. EXPERIMENTAL TEST RESULTS

The prototype is in operation in a trial home with various electrical appliances regularly: room heaters, microwave, oven, toasters, water kettle, fridge, television, audio device, battery chargers, and water pump. Total ten different types of electrical appliances are used in the experimental setup; though any electrical appliance who consumes power less than 2000W are selected to develop the system. Data collection is done by the smart coordinator who saves the collected data for processing purpose and for future use.

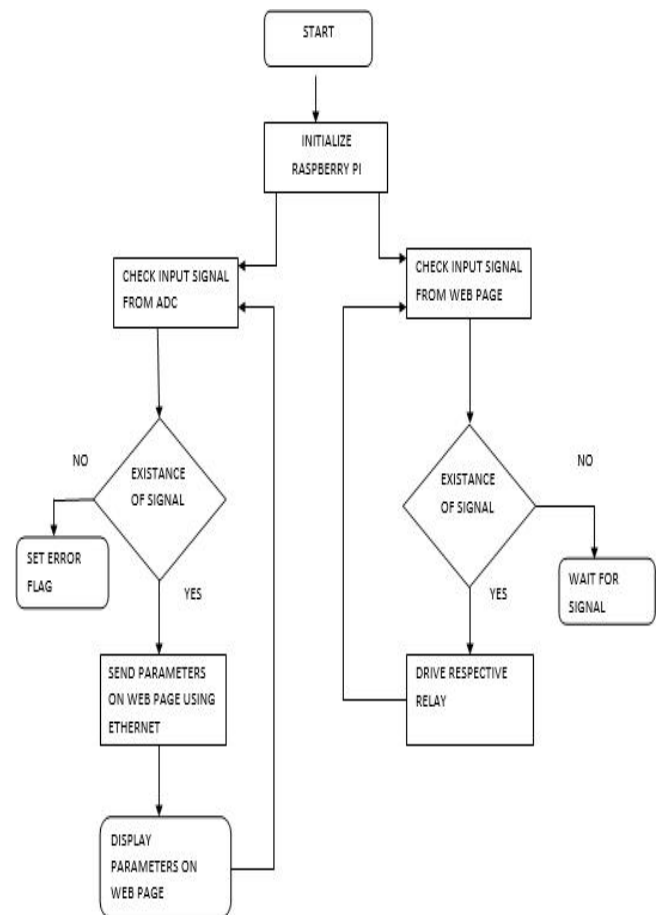

The parameters like voltage current and power are entered in the data coordinator in software from. These entered parameters will get stored in a database then analysed for result. Graphic user interface (GUI) window is used to. Displayed the result on the computer so that appropriate action can be taken from the GUI for proper monitoring. Fig. 7 shows the smart power monitoring and control system at a house where the system used.

V. RESULTS

This system is implemented and work as per requirement.

The sensor detects the Signal from field input it get processed and Appropriate action is taken by design System

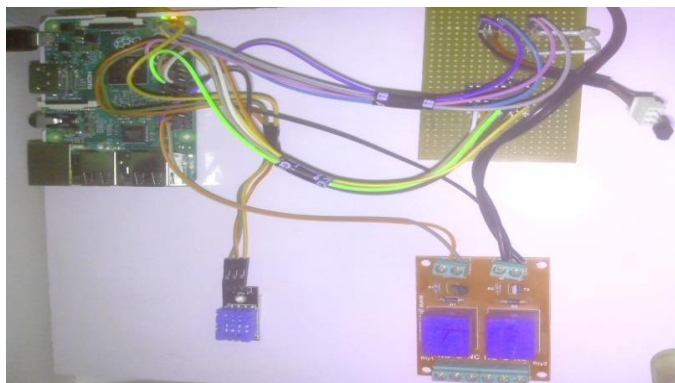
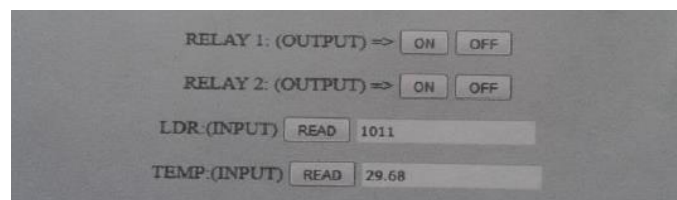

Figure 7: WSN node.



Monitoring the whole intelligent building. The aim behind the concept is to determine the areas of daily peak hours of electricity consumption levels and find out the best a solution by which we can lower the consumption and enhance better utilization of already limited resources during peak hours.

The system advantages are that it is robust and very flexible to used . For The last three months, the system was able to perform the remote monitoring and control of appliances effectively. Local and remote user interfaces are easy to handle by a novice consumer and are efficient in handling the operations.

REFERENCES

- [1] *Triacs-BT 138 Series, Philips Semiconductors* (accessed on 8 Jan. 2012). [Online]. Available: <http://docs-asia.electrocomponents.com/webdocs/0b4b/0900766b80b4bf38.pdf>
- [2] J. Han, C. S. Choi, and I. Lee, "More efficient home energy management System based on zigbee communication and infrared remote controls," *IEEE Trans. Consumer Electron.*, vol. 57, no. 1, pp. 85–89, Feb. 2011.
- [3] K. Gill, S. H. Yang, F. Yao, and X. Lu, "A zigbee-based home automation System," *IEEE Trans. Consumer Electron.*, vol. 55, no. 2, pp. 422–430, May 2009.
- [4] M. S. Pan, L. W. Yeh, Y. A. Chen, Y. H. Lin, and Y. C. Tseng, "A WSN based intelligent light control system considering user activities and profiles," *IEEE Sensors J.*, vol. 8, no. 10, pp. 1710–1721, Oct. 2008.
- [5] G. Song, Z. Wei, W. Zhang, and A. Song, "A hybrid sensor network system for home monitoring applications," *IEEE Trans. Consumer Electron.* vol. 53, no. 4, pp. 1434–1439, Nov. 2007.
- [6] C. Suh and Y. B. Ko, "Design and implementation of intelligent home Control systems based on active sensor networks," *IEEE Trans. Consumer Electron.* vol. 54, no. 3, pp. 1177–1184, Aug. 2008.
- [7] K. D. Nguyen, I. M. Chen, Z. Luo, S. H. Yeo,

and H. B. L. Duh, “A Wearable sensing system for tracking and monitoring of functional arm Movement,” *IEEE /ASME Trans. Mechatronics*, vol. 16, no. 2, pp. 213–220, Apr. 2011.

[8] W. Huiyong, W. Jingyang, and H. Min, “Building a smart home system With WSN and service robot,” in *Proc. 5th Int. Conf.*

Above Figure shows the Graphical user Interface for thecontrolling the devices based on sensors data.

Figure 8: Experimental Result

VI. CONCLUSION

Various user interfaces are used to programme the sensor networks suitable for users for different ability and for special or expert users such that the maintenance of the system become easy and interaction become simple. This work have the aim of to get the consumer’s response with respect to the smart technologies and advantages of deploying them also the possible concern related to the system, and overall view about the concept.

The monitoring of the electrical appliances can be taken in real time through the medium of internet and by using the website.. The system further is used for the purpose of

Measuring Technol. Mechatronics Autom., Hong Kong, China, 2013, pp. 353–356.

[9] N. K Suryadevara and S. C. Mukhopadhyay, “Wireless sensor networkBased home monitoring system for wellness determination of elderly,” *IEEE Sensors J.*, vol. 12, no. 6, pp. 1965–1972, Jun. 2012.