

A NOVEL CONVERTER FOR RENEWABLE ENERGY SOURCES INTEGRATION INTO MICRO GRIDS

¹M Dakshin Manaswin ²K Srinivas ³T. Ramapitchaiah

¹PG student, department of EEE in SSN Engineering College Ongole.

²HOD, department of EEE in SSN Engineering College Ongole.

³Principal, SSN Engineering College Ongole.

ABSTRACT

Renewable energy based distributed generators (DGs) play a dominant role in electricity production, with the increase in the global warming. Microgrids provide an ideal paradigm to form smart grids, thanks to their limited size and ability to ‘island’ when supplying most of their loads during emergencies, which improves system reliability. However, preserving load-generation balance is comprehensively challenging, given that microgrids are dominated by renewable-based DGs, which are characterized by their probabilistic nature and intermittent power. Although microgrids are now well-established and have been extensively studied, there is still some debate over having microgrids that are solely ac or solely dc, with the consensus tending toward hybrid ac-dc microgrids. This paper proposes an interlinking converter architecture, which enables flexibly integrating renewable energy into hybrid grids. The proposed converter has one AC port and two DC ports, offering a flexible solution to integrating various DC and AC sources, which can also be versatility configured as a DC-DC converter, a DC-AC inverter, or a DC-DC/AC multiport converter. The MATLAB/SIMULINK simulation results confirm the concept in terms of flexible conversion, high power density, low leakage currents as well as controllable power flow.

1. INTRODUCTION

I. Batarseh and K. Alluhaybi [1], the quantum improvement of battery technology in terms of cost, performance efficiency, and reliability paves the way for a new electric energy storage revolution. The new storage systems, when coupled with power electronics integration approaches, promise to cause a significant paradigm shift in power electronics technology, broadly expanding its application reach. Safe and reliable integration of photovoltaic (PV) panels, batteries, and power electronics in a single module is a powerful approach for meeting the challenging demands of the distributed solar energy market. Given recent advances in power electronics and battery technologies, one can now economically,

reliably, and safely integrate PVs, batteries, electronics, and protection within a single module.

B. T. Patterson [2], most discussions about ac versus dc electricity include a retelling of the famous technical and commercial battle between Edison and Westinghouse/Tesla. It's a story about everything from electrocuting elephants at state fairs to the ambitious work of electrifying both urban and rural America. It's the tale of one of man's greatest engineering feats. It tells of a centralized power generation system based on the dominant use of incandescent light bulbs and ac constant-speed motors. In the end though, it is a retelling of history and unfortunately, it is a history that doesn't project.

A. K. Bhattacharjee, N. Kutkut, and I. Batarseh [3], presents a comprehensive review of multiport converters for integrating solar energy with energy storage systems. With recent development of a battery as a viable energy storage device, the solar energy is transforming into a more reliable and steady source of power. Research and development of multiport converters is instrumental in enabling this transformation in an efficient manner. The high efficiency of conversion in comparatively smaller footprint makes a multiport converter very attractive in this application. Most of the recently reported multiport converter topologies are discussed here. A breakdown of isolated and no isolated topologies is presented along with the comparison of converter architectures and features such as operating conditions, device count, efficiency, etc. Each group of multiport converters is subdivided into different smaller groups based on their architecture. Detailed specifications are presented for important topologies. Finally, a performance comparison is carried out featuring the advantages and disadvantages of the various topologies leading to suggestions for the direction of future research.

J. Ramos-Ruiz, B. Wang, H. Chou, P. Enjeti, and L. Xie [4], presents a self-organizing power electronic converter with control intelligence at the edge of the distribution network is proposed. The proposed converter is called Power Electronics Intelligence at the Network Edge (PINE), it has the potential to add intelligence at the network edge to the electricity delivery system of the present and in the future. The proposed approach consists of a power electronic converter (rectifier/dclink/ inverter) termed as PINE to supply residential loads. The rooftop solar and battery energy storage system is connected to the dc-link. With the bidirectional characteristic of the PINE, the load voltage is regulated via feedback, while input distribution voltage can be allowed to vary in a range. This type of configuration allows for control of input power factor to be unity, reactive power to be injected at the grid edge to

regulate the voltage and also enable energy budgeting, i.e. limit the amount of power to the residential load under disaster situations. With the PINE converter at the distribution edge that can communicate with other PINEs as well as to the distribution system operator, intelligence at the distribution edge can be established. Such a system has many advantages that are discussed in the paper. Further, impacts of increased penetration levels of PINE are shown using a test feeder based on the IEEE-37 test node feeder.

F. Nejabatkhah and Y. W. Li [5], today, conventional power systems are evolving to modern smart grids, where interconnected microgrids may dominate the distribution system with high penetration of renewable energy and energy storage systems. The hybrid ac/dc systems with dc and ac sources/loads are considered to be the most possible future distribution or even transmission structures. For such hybrid ac/dc microgrids, power management strategies are one of the most critical operation aspects. This paper presents an overview of power management strategies for a hybrid ac/dc microgrid system, which includes different system structures (ac-coupled, dc-coupled, and ac-dc-coupled hybrid microgrids), different operation modes, a thorough study of various power management and control schemes in both steady state and transient conditions, and examples of power management and control strategies. Finally, discussion and recommendations of power management strategies for the further research are presented.

2. PROPOSED INTERLINKING CONVERTER

The general concept of the proposed interlinking converter architecture for hybrid grids is shown in Fig. 1. As seen in Fig. 1, the converter has two DC ports and one AC port, where the low-voltage DC (DCL) side can be PV panels, batteries or other RESs, and the high-voltage DC (DCH) side can be connected to a DC grid or loads (also storages). Similarly, the AC side can be an AC load or an AC grid. Notably, all the power conversions in the proposed architecture should be bidirectional for high flexibility. To realize so, the following should be considered: 1) The control switch of the boost converter is replaced by a VSI with its common-mode voltage (CMV) being clamped to achieve the AC output; 2) An active switch, i.e., a synchronous rectifier switch, is adopted for the bidirectional DC-DC conversion, and accordingly, the hybrid converter can achieve boost or buck conversion between the DCL and the DCH sides; 3) A symmetrical impedance network (SIN) is placed at the DCL side, as exemplified in Fig. 1, which is also essential to lower the leakage currents.

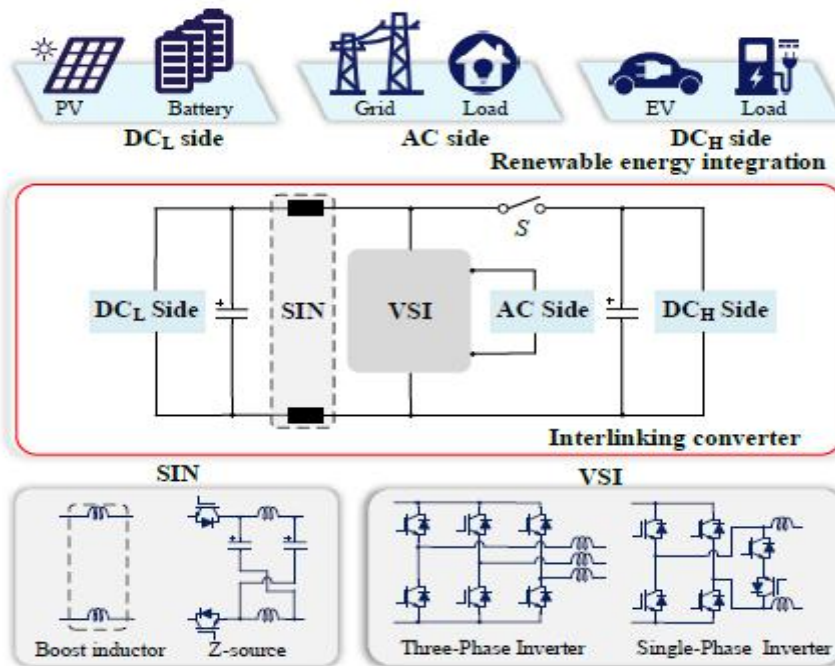

Figure 1: General concept of the proposed interlinking converter architecture, where S represents an active switch, allowing the bidirectional power flow.

In such architecture, the CMV will be clamped to be half of the DCL voltage by the symmetrically arranged impedance and the VSI. To demonstrate the CMV clamping, the proposed interlinking converter architecture with a single-phase inverter is exemplified as shown in Fig. 2.

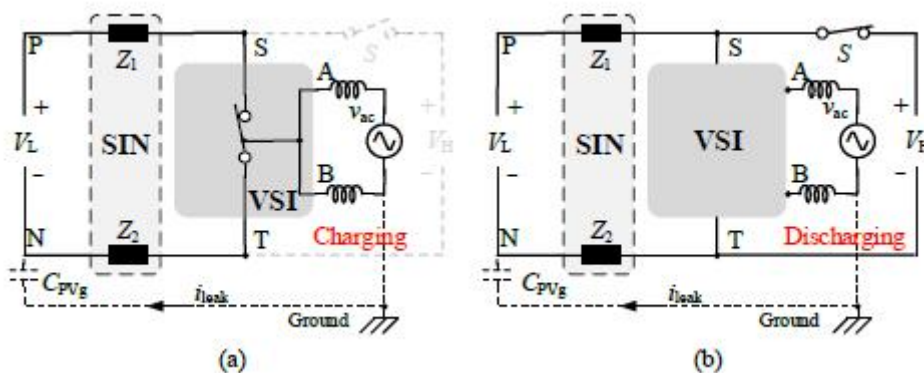

Figure 2: Operational states of the proposed interlinking converter architecture with a single-phase inverter: (a) charging state and (b) discharging state

where Z_1 and Z_2 are the equivalent impedances of the SIN ($Z_1 = Z_2$), P and N are the positive and negative terminals of the DCL side, S and T are the positive and negative input terminals of the VSI, A and B are the output terminals of the VSI, V_L , V_H and v_{AC} are the DCL voltage, the DCH voltage and the AC voltage, C_{PVg} and i_{leak} are the PV parasitic capacitor and the leakage current.

As observed in Fig. 2, there are two modes, i.e., the charging and discharging states of the SIN, which are defined as follows: (1) During the charging period, the VSI operates in shoot through (ST) mode and the active switch S is OFF, as depicted in Fig. 2(a). Accordingly, the terminal voltages are $v_{AN} = v_{BN} = V_L = 2$, and the CMV v_{cm} [12] is calculated as

$$v_{cm} = \frac{v_{AN} + v_{BN}}{2} = \frac{V_L}{2}$$

As presented in Fig. 2(b), the SIN is discharging, the VSI operates in the DC-AC conversion mode, and S is in ON-state. Due to the CMV (denoted as v_{cmVSI}) being already clamped by the adopted VSI $v_{cmVSI} = (v_{AT} + v_{BT}) = 2 = V_H = 2$. Considering the terminal voltage $v_{AN} = v_{AT} - V_{Z2}$, $v_{BN} = v_{BT} - V_{Z2}$, the resultant CMV of the proposed converter can be obtained as

$$\begin{aligned} v_{cm} &= \frac{v_{AN} + v_{BN}}{2} = \frac{(v_{AT} - V_{Z2}) + (v_{BT} - V_{Z2})}{2} \\ &= \frac{V_H - (V_{Z1} + V_{Z2})}{2} = \frac{V_L}{2} \end{aligned}$$

where V_{Z1} and V_{Z2} are the SIN voltages, i.e., $V_{Z1} = V_{Z2}$. It can be observed from Eqs. (1) and (2) that the proposed interlinking conversion architecture can maintain a constant CMV due to the employment of the SIN and the VSI with its CMV being clamped. Thus, the proposed interlinking converter is suitable for PV applications. It is worth noting that the leakage current suppression can only be achieved at the DCL side. Additional isolation equipment can be considered at the DCH side according to application requirements (e.g., in a DC grid).

2.1. Operational Flexibility

As shown in Fig. 1, the adoption of the synchronous rectifier switch enables the bidirectional power flow between the DC ports. Furthermore, the VSI can also achieve reactive power injection with a dedicated modulation method, where the power factor can be adjusted between $[-1, 1]$. In all, the proposed hybrid converter has high flexibility and controllability for RES integration into hybrid grids. As shown in Fig. 3, the flexibility is reflected by the possible operation modes, which include: the power feed-in mode (Mode I), the power feedback mode (Mode II), and the power factor mode (Mode III):

(1) In Mode I, the DCL side is a source (e.g., PV panels) to provide power to the DCH side, the AC side or both. In this case, the converter achieves the boost DC-DC conversion and

DC-AC conversion from the DCL side to the DCH and the AC sides, respectively. Additionally, in this mode, both the DCL and the DCH/AC sides can feed power into the AC/DCH side.

(2) In Mode II, there are three operation cases. Firstly, the power from the AC side is fed back to the DCL and DCH sides (i.e., the two DC ports are loads), where the converter operates in the active rectification for the DCH side and the buck DC-DC conversion for the DCL side from the AC side. Secondly, the power feed-back mode is the case where only the DCL side is working as a load (e.g., charging batteries). That is, both the DCH and AC sides are providing power. Thirdly, both the DCL and the AC sides are acting as loads, where the DCH side should perform the buck DC-DC and the DC-AC conversions, respectively.

(3) In Mode III, whatever power flow modes between the DCL and DCH sides are, the power factor at the AC side should be controlled flexibly to enable grid-connected applications. The proposed converter architecture can achieve so when the modulation method for the DC-AC conversion has reactive power injection capability, as indicated in Fig. 3.

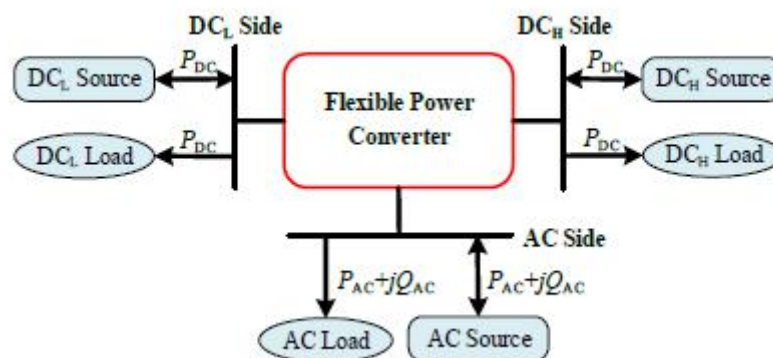

Figure 3: . Possible operation modes of the proposed interlinking conversion architecture, where P_{AC} and Q_{AC} represent the corresponding active power and reactive power at the AC port.

When applied in a hybrid AC/DC grid (i.e., the AC and DCH ports are connected to grids), the overall system operation can be enhanced to a large extent. For instance, when the AC grid requires support (e.g., to tackle the frequency stability), the active power from the input DCL side can be regulated, while the DCH grid can also provide support by feeding power to the AC port. Similarly, if the DC side has stability issues under faults (e.g., under voltage issues), the AC grid can be operated in the rectification mode to help the DC grid withstand the fault. In all, the proposed power conversion architecture can be a flexible and promising solution to the integrating of RESs into hybrid AC/DC grids.

Topology and Modulation Example

A modulation strategy for the proposed architecture is further demonstrated on an exemplified converter using a highly efficient and reliable inverter concept (HERIC) inverter as the VSI and a symmetrical inductor network as the SIN, which is shown in Fig. 4.

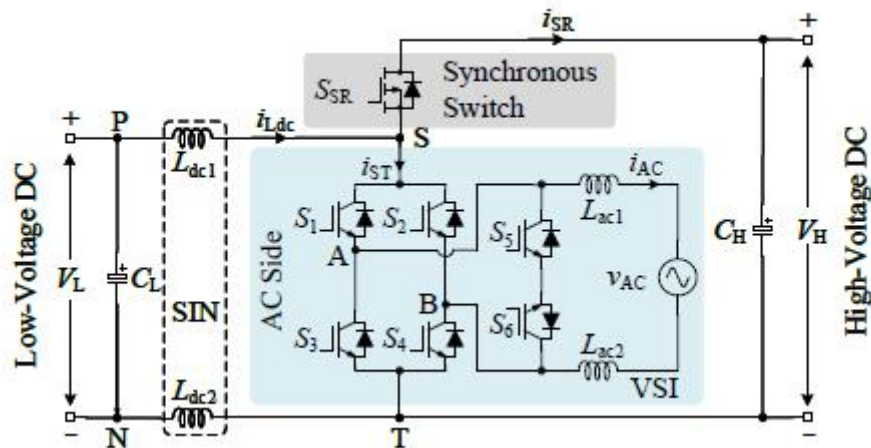

Figure 4: highly efficient and reliable inverter concept (HERIC) inverter

An example of the proposed interlinking conversion architecture using a symmetrical boost inductor network and an HERIC, where SSR is the synchronous rectifier switch, the boost inductors are L_{dc1} , L_{dc2} , (i.e., $L_{dc1} = L_{dc2}$), C_L and C_H are the DC capacitors, i_{dc} , i_{ST} and i_{SR} are the DC inductor current, the VSI input current and the synchronous rectifier switch current, i_{AC} is the current of the L-type filter (i.e., including L_{ac1} and L_{ac2} , $L_{ac1} = L_{ac2}$), and its positive direction is from the VSI to the AC grid.

Discussions

Although the proposed architecture has high flexibility, there are certain concerns in terms of conversion ratio, control and efficiency. Those can be further explored as future work to improve the performance of hybrid converters for integrating various renewable sources. When designing the system, those aspects should also be considered:

(1) Conversion Ratio. As shown in Eqs. (3) and (5), the conversion ratios are limited. To solve this issue, a symmetrical high-boosting impedance network, switched-inductor or others can be adopted.

(2) System Control. Notably, the control of the proposed converter varies in applications. The currents are the control objectives when the ports connected to energy sources, while the

voltages are controlled when the ports supplying loads. For instance, the proposed converter operates in Mode I, where the DCL side is the source, the DCH side is the load and the AC side is a grid. In this case, a proportional-integral (PI) controller can be adopted as the voltage control-loop for the DC-DC conversion, and a proportional-resonant (PR) controller can be used for the DC-AC conversion, respectively. In addition, due to the power coupling between the DC and AC sides, both DC ports have pulsating ripples. This is also common in conventional single-phase VSI systems, the strategies for which to mitigate the ripples may also be applied to the proposed converter. Moreover, the MPPT control of the proposed converter can be achieved flexibly, i.e., obtained in the DC-DC conversion, the DC-AC conversion or both.

(3) Power Density. The proposed interlinking converter can improve the power density due to: 1) fewer power devices to obtain multiple outputs when compared to the conventional two-stage inverter; 2) smaller AC filter inductors compared to the transformer less hybrid converter with the dual-buck inverter as the VSI; 3) symmetrically distributed boost inductors, resulting in lower leakage currents (thus, good power quality); 4) higher efficiency leading to a smaller heatsink, as mentioned in the above. In all, it is confirmed that the proposed converter has superior performances than the conventional two-stage solution.

3. SIMULATION RESULTS

Case-1:-

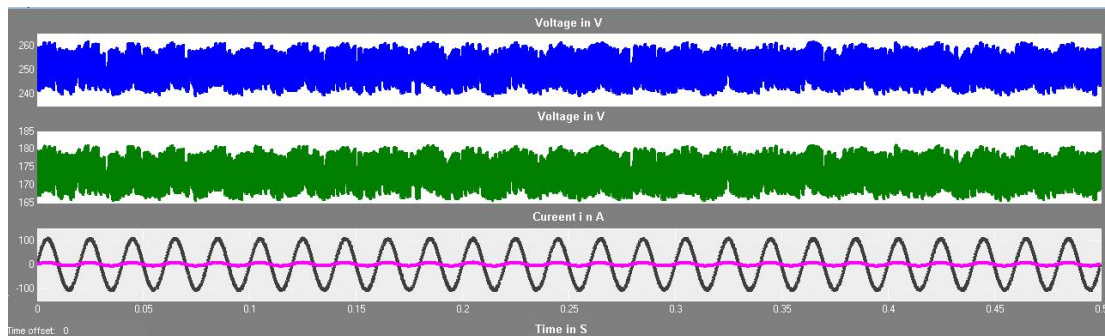
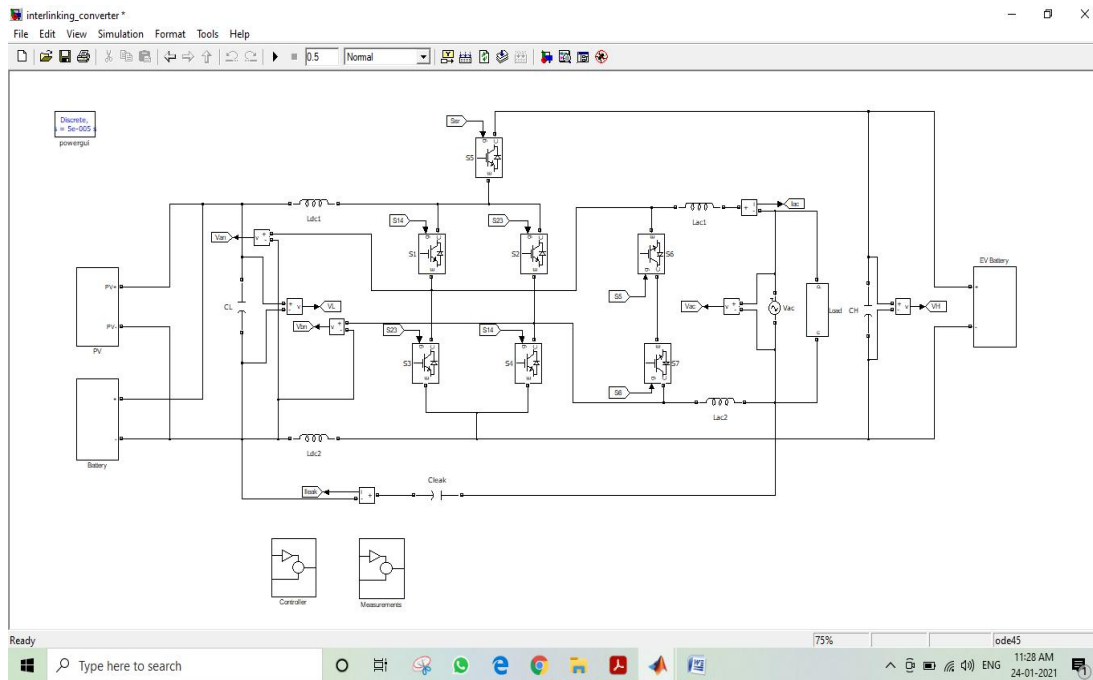

Figure 5: : case 1 Simulation output

Fig. 5. Performance of the proposed interlinking converter with an HERIC as the VSI operating in Mode I

The performance of the proposed converter in Mode I is shown in Fig. 5, where the DCL side provides power to the DCH side and the AC output. As shown in Fig. 5, the proposed architecture can provide an AC and DC outputs simultaneously. In addition, as mentioned in Section II.D, both DC voltages have ripples in Fig. 6 due to the power coupling and also the characteristics of the commercial DC source (i.e., having an internal resistance and a large output capacitor). The power decoupling strategies for the conventional VSI may also be applied to alleviate this.

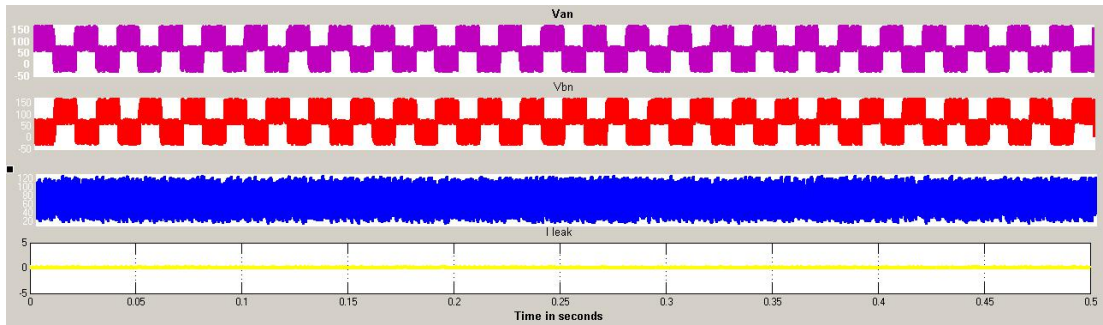

Figure 6:Performance of the proposed converter, where v_{AN} and v_{BN} are the voltage of the terminals A and B to N, respectively, and v_{cm} and I_{leak} are the CMV and the leakage current

Fig. 6 demonstrates the CMV and leakage currents of the proposed converter for PV applications. As shown in Fig. 6, the leakage current i_{leak} is below the limit. Additionally, it is illustrated by the inverter voltage V_{AN} and V_{BN} in Fig. 6 that the adopted modulation method can achieve the same performance as the HERIC with the unipolar PWM. Thus, the proposed converter can maintain low leakage currents and good power quality.

Case-2:-

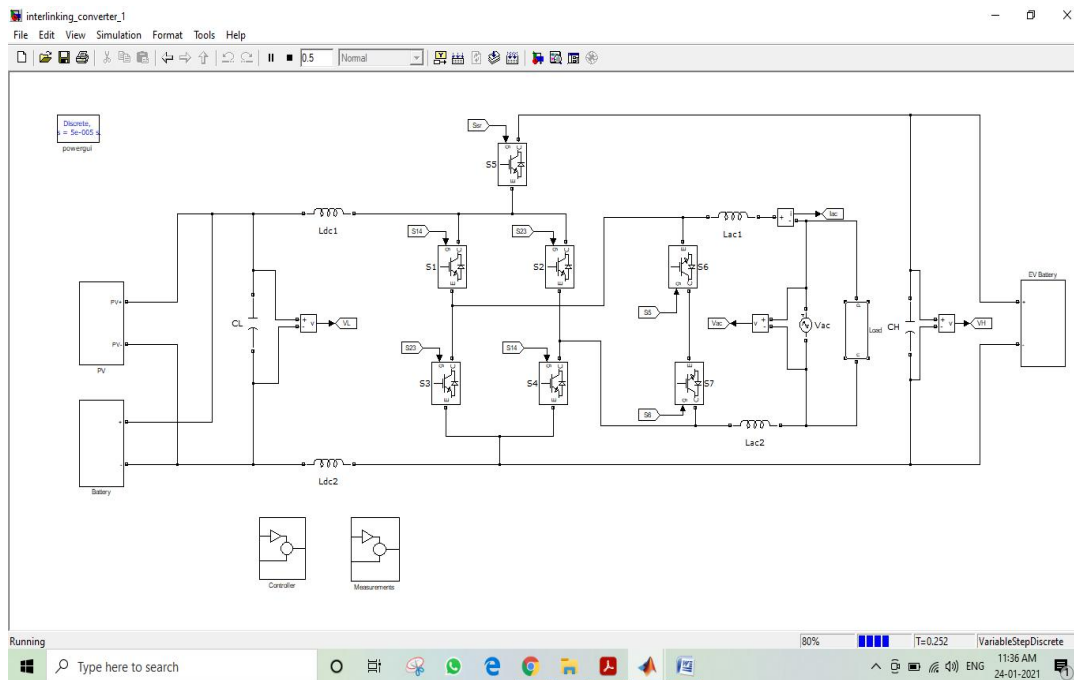

Figure7: : case 2 Simulation output

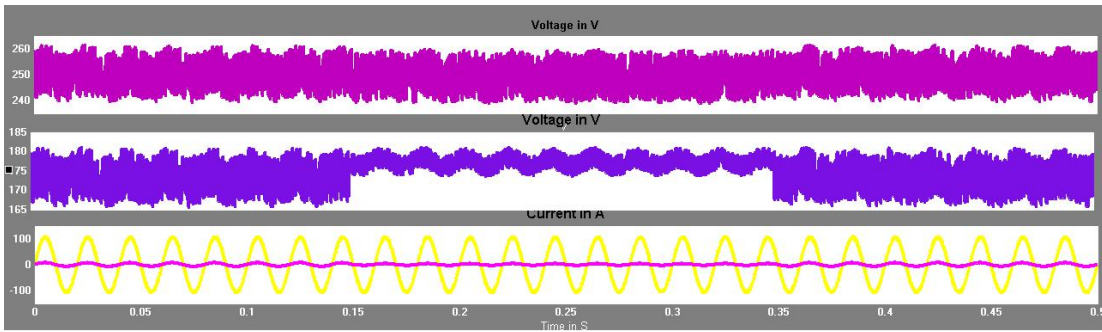

Figure8: Performance of the proposed interlinking converter under load step changes at the AC side in Mode

Moreover, the dynamic performance of the converter in Mode I has been tested under an AC load change. As shown in Fig.8, the grid current amplitude (RMS) was changed to 2.5 A and then back to 5 A. The experimental results indicate that the proposed converter can operate stably under dynamic load changes. More importantly, due to the separated control of the DC-DC and DC-AC conversions, the current quality is not affected by the load changes.

Case-3:-

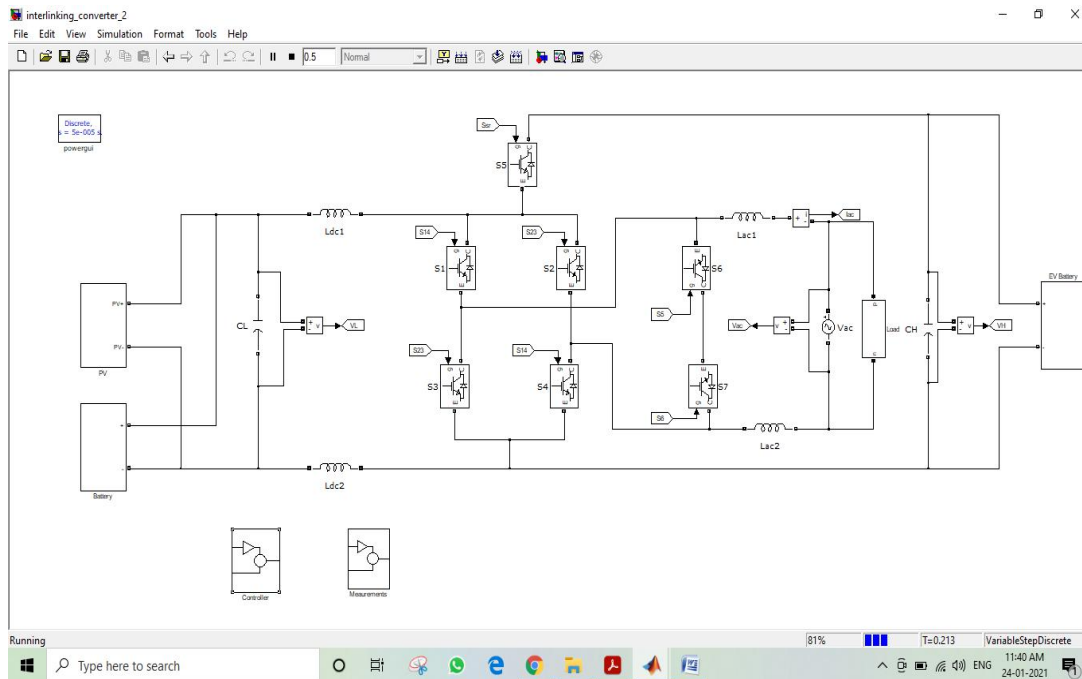

Figure9: Case-3 Simulation diagram

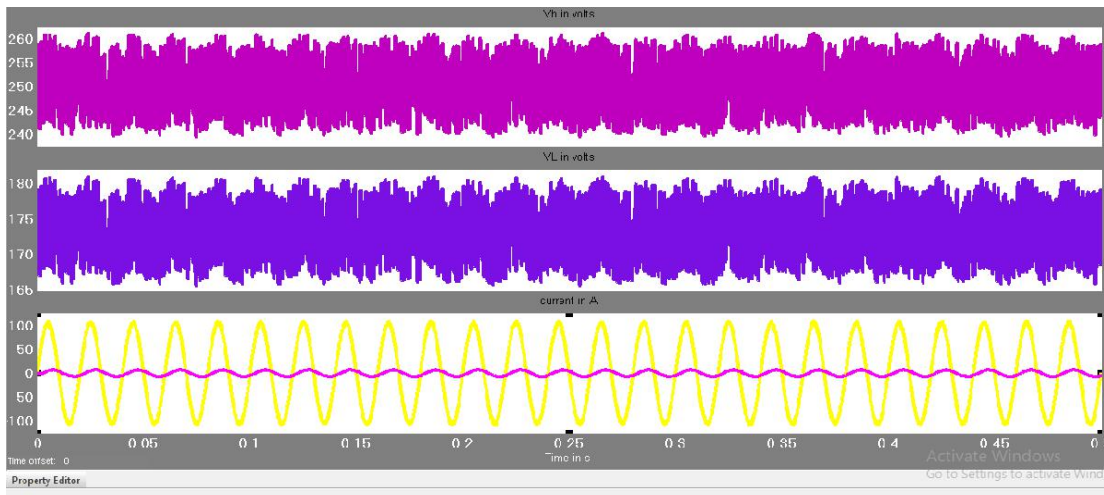

Figure 10: Case-3 Simulation output

To further validate the performance of the proposed converter, simulation tests in Mode III are carried out and the results are shown in Fig. 10, where the DC-AC conversion operates under a non-unity power factor. Observations in Fig. 10 indicate that the proposed converter can provide flexible reactive power injection, which may be beneficial to the entire system operation (e.g., to provide grid support).

4. CONCLUSION

In this project, interlinking conversion architecture was proposed as a promising solution to the integration of various energy sources into hybrid grids. The proposed architecture is implemented by replacing the power devices in the boost converter with a VSI and an active switch. The proposed interlinking conversion architecture can achieve low leakage currents, good power quality, high efficiency, and flexible power flow control. MATLAB/SIMULINK simulation results have verified the performance of the proposed architecture. As the demand of hybrid energy systems is increasing, the flexible power conversion architecture could be a promising interlinking stage.

5. REFERENCES

- [1] I. Batarseh and K. Alluhaybi, “Emerging opportunities in distributed power electronics and battery integration,” *IEEE Power Electron. Mag.*, vol. 7, no. 2, pp. 22–32, Jun. 2020.

- [2] B. T. Patterson, "DC, come home: DC microgrids and the birth of the Enernet," *IEEE Power Energy Mag.*, vol. 10, no. 6, pp. 60–69, Nov. 2012.
- [3] A. K. Bhattacharjee, N. Kutkut, and I. Batarseh, "Review of multiport converters for solar and energy storage integration," *IEEE Trans. On Power Electron.*, vol. 34, no. 2, pp. 1431–1445, Feb. 2019.
- [4] J. Ramos-Ruiz, B. Wang, H. Chou, P. Enjeti, and L. Xie, "Power electronics intelligence at the network edge (PINE) – an approach to interface PV and battery energy storage systems at the grid edge," *IEEE J. Emerg. Sel. Top. Power Electron.*, pp. 1–1, 2020.
- [5] D. D'Agostino, P. Zangheri, B. Cuniberti, D. Paci, and P. Bertoldi, "Synthesis report on the national plans for nearly zero energy buildings (NZEBs)," EUR 27804 EN.
- [6] F. Nejabatkhah and Y. W. Li, "Overview of power management strategies of hybrid AC/DC microgrid," *IEEE Trans. Power Electron.*, vol. 30, no. 12, pp. 7072–7089, Dec. 2015.
- [7] H. Ribeiro, A. Pinto, and B. Borges, "Single-stage DC-AC converter for photovoltaic systems," in *Prof. of ECCE*, Sep. 2010, pp. 604–610.
- [8] A. Abdelhakim, P. Mattavelli, P. Davari, and F. Blaabjerg, "Performance evaluation of the single-phase split-source inverter using an alternative DC-AC configuration," *IEEE Trans. Ind. Electron.*, vol. 65, no. 1, pp. 363–373, Jan. 2018.
- [9] S. S. Lee and Y. E. Heng, "Improved single-phase split-source inverter with hybrid quasi-sinusoidal and constant PWM," *IEEE Trans. Ind. Electron.*, vol. 64, no. 3, pp. 2024–2031, Mar. 2017.
- [10] S. S. Lee, A. S. T. Tan, D. Ishak, and R. Mohd-Mokhtar, "Singlephase simplified split-source inverter (S3I) for boost DC-AC power conversion," *IEEE Trans. Ind. Electron.*, vol. 66, no. 10, pp. 7643–7652, Oct. 2019.
- [11] O. Ray and S. Mishra, "Boost-derived hybrid converter with simultaneous DC and AC outputs," *IEEE Trans. Ind. Appl.*, vol. 50, no. 2, pp. 1082–1093, Mar. 2014.
- [12] S. Dey, V. K. Bussa, and R. K. Singh, "Transformerless hybrid converter with AC and DC outputs and reduced leakage current," *IEEE J. Emerg. Sel. Top. Power Electron.*, vol. 7, no. 2, pp. 1329–1341, Jun. 2019.
- [13] Z. Tang, Y. Yang, M. Su, H. Han, and F. Blaabjerg, "A symmetrical transformerless hybrid converter with leakage current suppression," in *Prof. of ECCE*, Sep. 2019, pp. 6680–6685.

- [14] Z. Tang, Y. Yang, M. Su, T. Jiang, F. Blaabjerg, H. Dan, and X. Liang, "Modulation for the AVC-HERIC inverter to compensate for dead time and minimum pulsewidth limitation distortions," *IEEE Trans. Power Electron.*, vol. 35, no. 3, pp. 2571–2584, Mar. 2020.
- [15] S. Heribert, S. Christoph, and K. Jurgen, "Inverter for transforming a DC voltage into an AC current or an AC voltage," *Europe Patent 1 369 985 (A2)*, May, 2003.
- [16] K. Li, Y. Shen, Y. Yang, Z. Qin, and F. Blaabjerg, "A transformerless single-phase symmetrical Z-source HERIC inverter with reduced leakage currents for PV systems," in *Proc. of APEC*, Mar. 2018, pp. 356–361.
- [17] B. Axelrod, Y. Berkovich, and A. Ioinovici, "Switchedcapacitor/ switched-inductor structures for getting transformer less hybrid DC–DC PWM converters," *IEEE Trans. Circuits Syst. I, Reg. Papers*, vol. 55, no. 2, pp. 687–696, Mar. 2008.