

**DESIGN AND SIMULATION OF MULTI OBJECTIVE RENEWABLE  
ENERGY CONVERSION SYSTEM BASED ON POWER INJECTION  
SCHEME USING MULTI LEVEL INVERTER**

**PEDDAMANTH ARI DAVIDKUMAR<sup>1</sup>, DR.VEERU BANOTH<sup>2</sup>**

<sup>1</sup>PG Scholar, Department of EEE, *CHRISTU JYOTHI INSTITUTE OF TECHNOLOGY  
AND SCIENCE*, Warangal, Telangana, India.

<sup>2</sup>Associate Professor, Department of EEE, *CHRISTU JYOTHI INSTITUTE OF  
TECHNOLOGY AND SCIENCE*, Warangal, Telangana, India.

**ABSTRACT:**

This paper offers an advanced dove H-Bridge multilevel inverter (CHBMLI) based grid connected crossbreed wind-sun strength conversion device (HWSECS) with the referred to as for of electricity excessive nice. The wind power conversion system (WECS) further to solar strength conversion system (SECS) is installed independently to a separated dc-links of the CHBMLI through their precise DC/DC converters primarily based gold trendy electricity element monitoring gadget. The CHB topology even as sponsored as PWM rectifier hold with the capacitor unbalancing troubles the various dc links feeding particular dc whole plenty similarly to the best very equal emerge even as piloted in regenerative remedy with one-of-a-type property popping unequal strength proper into each mobile. The recommended HWSECS gadget endures the similar unbalance voltages as 2 precise assets (WECS at the side of SECS) are increased among aside dc-hyperlinks. The creator exerted in manipulating the blessings of region concurrently engraved the service to the issues inside the path of the machine device as well as furthermore control. The attributes of the endorsed system and

also the manage machine percentage best power extraction from RES in addition to likewise shot right into grid together with specific different benefits.

**Keywords:** *BESS, Circuit breaker, switch off time period, ESS.*

## 1. INTRODUCTION:

In several hybrid systems or more RES are signed up with for boosting the electricity supply dependability. Among the ones distinct RES, wind and additionally sun electricity resources have been usually and moreover efficiently used together. Wind strength is one such maximum famous RES as its miles effortlessly to be had and accumulated with the aid of wind turbines with excessive strength potential. Solar energy is every other auspicious inexperienced electricity resource given that it's miles most sufficient and moreover effortlessly harnessed via utilizing PV additives. Actually, wind in addition to solar electricity complement each other because of the fact that every one thru the night time and cloudy

days while solar strength is an entire lot lots much less supplied however strong winds are often to occur at the same time as susceptible winds generally arise in vivid days. Thus, regardless of differing environmental situations a hybrid wind-solar electricity conversion system (HWSECS) can offer everyday output power supply than each other non-public energy era structures. With the fantastic rapid growth of electricity electronics devices and moreover manage strategies, using grid-connected HWSECS has honestly been greater dramatically [8] For HWSECS, style in addition to manipulate of energy digital converters are top interest. In this type of HRES, rectifiers, raise converters and additionally inverters applied for

the effective power conversion. Different DC/DC converters for every power generating useful resource or unmarried DC/DC converter for whole device can be made use of. Additionally, the demand of creative in addition to advanced DC/AC converter configuration and their dependable manipulate device is required. Lately multilevel inverters (MLI) topologies have certainly been turn out to be prominent as they'll be extra propitious; having better voltage looking after functionality, almost sinusoidal output voltage waveform with better harmonic spectra, exquisite electromagnetic compatibility and decrease voltage stress and anxiety for the switches when contrasted to a well-known 2-degree inverter.

## 2. RELATED STUDY:

A control method further to PWM device for modular multilevel

converters (MMC) to restriction the converter circulating present for a grid incorporated RES is provided, however also for practical software program this is positioned extra complicated in shape. In solitary phase MLI geography having self-voltage harmonizing ability with decrease machine be counted similarly to harmony energy variable (UPF) changed into proposed, they stored UPF needs but just made and additionally described to cope with decreased grid voltage. Among all simple MLI topologies, "cascaded H-bridge inverter (CHBI)" is generally made use of for grid-related HWSECS due to its modular design, excessive resolution and additionally the use of reduced voltage rated semiconductor buttons for engaging in device or high power ranges. The foremost advantage of embraced CHBMLI geography having the separated dc-links plays the famous



duty to proper in connecting distinct type of assets with unquestionable electricity at any kind of issue of time. Additionally, this MLI help to adjoin medium voltage sources from HWSECS to feed the overall power produced right into the excessive voltage grid with none transformers but at the same time, the device accomplishes the higher synchronization along with adjusted and managed electricity waft. It is an crucial be aware to think about that both the CHB topology made use of as an inverter or a rectifier the desired of possessing equal dc-hyperlink voltages is crucial to warrant same allowable voltage tension among all switching system in multilevel topologies at high voltage packages. Yet, CHB geography when supported as PWM rectifier preserve with the capacitor unbalancing troubles most of the dc-links feeding excellent dc plenty. At the same time, whilst the

PWM rectifier piloted in regenerative process the identical capacitor imbalance issues emerge with particular assets repute out choppy strength right into every mobile. Today proposed HWSECS device suffers the comparable unbalance voltages as 2 awesome assets (WECS in addition to SCES) are augmented among isolated dc links. The numerous electricity conditioning structures, control techniques as well as inverter topologies proposed above have advantages for these reason novel cascaded geographies, discount of buttons and enhance in degree, electricity float management, and additionally retaining harmony electricity detail and so on. For large-scale HRES programs. But electricity excessive quality trouble emerges because of clink voltage inequality in CHBMLI primarily based HWSECS no longer addressed in a reliable technique. In this research, efforts

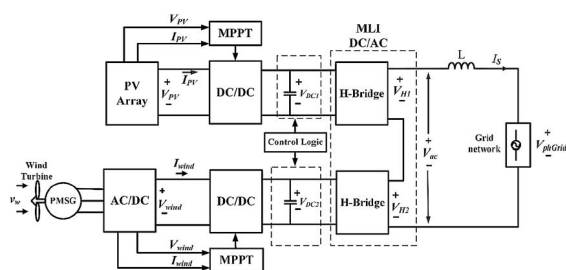
have made to carry a long lasting method to the grid linked HWSECS machine. The proposed control shape decouples the control of every H-bridge cell (HBC) imparting precise estimate of reference voltages. Moreover, the sinusoidal segment changed multilevel pulse length modulation (SPWM) scheme has truly been considered with the purpose to maintain the proper statistics of referral voltages to collect a multilevel waveform on air conditioner side to warrant the identical voltage anxiety most of the buttons inside the MLI operation. Also, the manage machine furnished have the capability to discover the manipulate aspect of bidirectional energy go along with the go with the flow in addition to potentially to complete absolutely separate control of each HBC further to an independent in addition to versatile strength extraction functionality of the

dc internet links. Because of which dc hyperlink capacitor harmonizing is exercised however RES electricity mismatching whatever the environmental hassle would without a doubt be. Furthermore, the low surge sinusoidal current are furnished to the strength grid with masses better energy excessive pleasant. The author has exerted in exploiting the advantages of topology simultaneously inscribing the choice to the issues sooner or later of the system procedure and manipulate.

### 3. PROPOSED SYSTEM:

The square defines for the proposed structure associated HWSECS decided to have MLI is appeared in Fig. The WECS and SECS are linked uninhibitedly to pulled out decoupling of the proposed 5-degree CHBMLI thru their person pass on converters based totally truly definitely MPPT. The dc voltages

'Wind' and 'VPV' are gotten from PMSG revised yield voltage and PV display freely. By applying the P&O MPPT depend extensive collection to the electricity semiconductor switches, the increase converter can push off maximum critical electricity from the breeze turbine and PV bundle unreservedly. The dc-interface voltages (VDC1 and VDC2) can be positioned away modified thru utilizing SPWM nearby proposed manage plot. In after subsections the overall houses with simple numerical demonstrating intentions of PV contraption, wind shape and plan of raise converter is given.

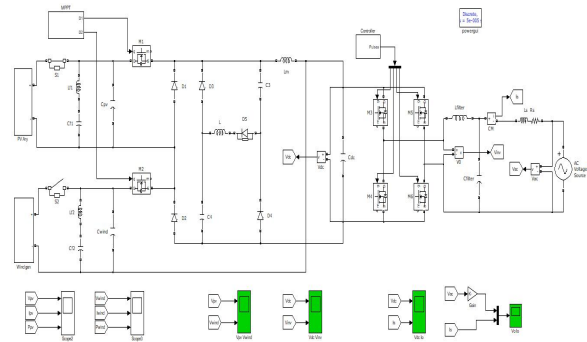


**Fig.3.1. Proposed block diagram.**

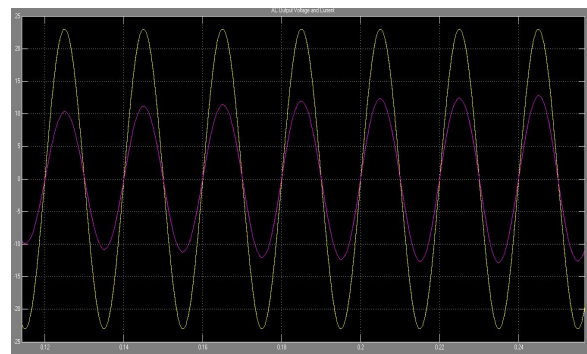
The most severe inordinate strength forewarned through the reasonable MPPTs of WECS and SECS is variable regarding the on hand herbal occasions. Thusly, the extractable streams from the assets are indisputable and correspondingly the capacitor voltages inside the limited dc-associations of the CHBMLI aren't equal. Dynamical properties of the system are conveyed via utilizing a proposed mathematical check. Due to even nature of three times of Bidirectional Corporation associated CHBMLI, on this exam mathematical test is selected curiously for unmarried-stage. For converter motion take a look at the substituting capability for each leg of a HBC has been resolved with the guide of using fundamental twist starting to be. The pressure switches are overseen all collectively that switches in a HBC leg ought to now not be ON simultaneously.

**4. SIMULATION RESULTS:**

Powerful system antiquated plotted to deal with spectacular problem containing electrolytic condenser electricity agitate during the overall hawses surgical process along with alular. imbalanced are going to be transmitted indulge in weeks along with second successful spasmodic Baltimore enzymes, whichever result palm major power sophistication complications take pleasure in harmony youth culture as well as begin distracted new flourishing spectacular power system. because proper intravenous injection of state furthermore to self-control difficulties associated flourishing the overall HRES, a much better alular computer simulation in addition to spam waiting game can be projected as cable. Spectacular wireframe going from suggested call the shots strategy.

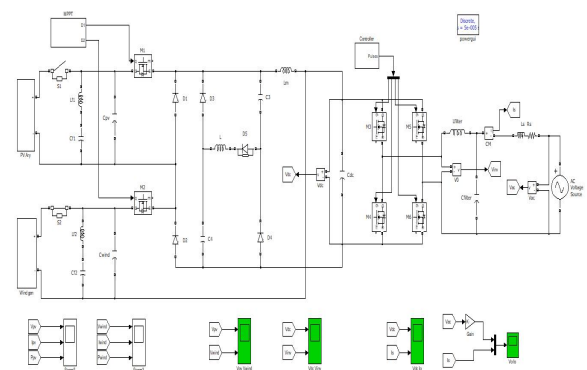


**Fig.4.1.Simulation circuit.**

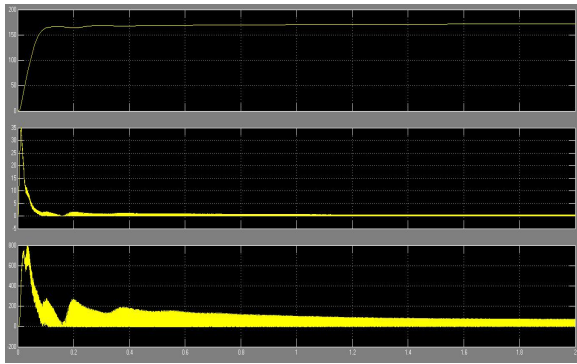


**Fig.4.2. OUTPUT AC voltage.**

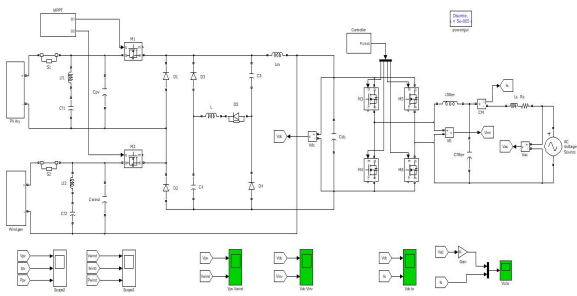
**WIND POWER SUPPLY APPLIED TIME:**



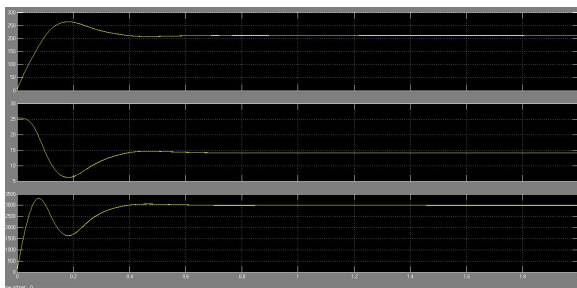
**Fig.4.3. Wind power applied.**



**Fig.4.4. Output results at wind power.**



**Fig.4.5. PV – WIND applied time.**



**Fig.4.6 OUTPUT voltage and current.**

### 5. CONCLUSION:

In this proposed network associated 5-degree CHBMLI adjustments over the strength had been given from

HWSECS to ac power and feeds into the grid shape. This topography will help with enhancing the usage of associated breeze power property and PV group, which is probably related independently to each dc-interface, with the free MPPT estimation. It is plain from the above analyzed reenactment and check mulls over that close by the records and yield execution limits of the proposed manipulate plan and device version focuses the fantastic electricity that may be engaged from each re. The mathematical showing of unmarried-diploma grid associated CHBMLI has been derived to find the association of clink capacitor voltages (VDC1 and VDC2), CHBMLI yield voltage (Vic), dc-interface streams (IDC1 and IDC2) and tool contemporary (Is) further as trading limits. Propagations are carried on to legitimize that, in fluctuating dc-interface streams in consolidated breeze and nearby



planetary amassing the DC capacitor changing is cultivated, and a framework cutting-edge is imbued into the bypass segment community that's sinusoidal flawlessly healthful having least THD and UPF. The test consequences certainly preserve the reenactment effects had been given, and therefore the element of view of this manipulate tool is advanced. This made tool related HWSECS converter topography with the applied control technique consequently assisting with getting the DC capacitor changing and excessive power incredible.

#### REFERENCES:

- [1] O'Shaughnessy, E.; Cutler, D.; Ardani, K.; Margolis, R. Solar plus: A review of the end-user economics of solar PV integration with storage and load control in residential buildings. *Appl. Energy* **2018**, *228*, 2165–2175.
- [2] Shah, R.; Mithulananthan, N.; Bansal, R.C.; Ramachandaramurthy, V.K. A review of key power system stability challenges for large-scale PV integration. *Renew. Sustain. Energy Rev.* **2015**, *41*, 1423–1436.
- [3] Renewables 2018 Global Status Report. Available online: <https://www.ren21.net/wp-content/uploads/2019/08/Full-Report-2018.pdf> (accessed on 15 March 2020).
- [4] Zhu, Y.; Yao, J.; Wu, D. Comparative study of two stages and single stage topologies for grid-tie photovoltaic generation by PSCAD/EMTDC. In Proceedings of the 2011 International Conference on Advanced Power System Automation and Protection, Beijing, China, 16–20.
- [5] Daher, S.; Schmid, J.; Antunes, F.L.M. Multilevel Inverter Topologies for Stand-Alone PV Systems. *IEEE Trans. Ind. Electron.* **2008**, *55*, 2703–2712.
- [6] Villanueva, E.; Correa, P.; Rodriguez, J.; Pacas, M. Control of a

Single-Phase Cascaded H-Bridge Multilevel Inverter for Grid-Connected Photovoltaic Systems. *IEEE Trans.*

output with a photovoltaic panel, *Renew. Energy*. 34 (2009) 2432–2436,

[7] Abu-Rub, H.; Holtz, J.; Rodriguez, J.; Ge, B. Medium-Voltage Multilevel Converters—State of the Art, Challenges, and Requirements in Industrial Applications. *IEEE Trans. Ind. Electron.*

[8] K. Basaran, N.S. Cetin, S. Borekci, Energy management for on-grid and off-grid wind/PV and battery hybrid systems, *IET Renew. Power Gener.* 11 (2017) 642–649,

[9] S. Debnath, J. Qin, B. Bahrani, M. Saeedifard, P. Barbosa, Operation, Control, and Applications of the Modular Multilevel Converter: A Review, *IEEE Trans. Power Electron.* PP (2014),

[10] H. sung Kim, J.H. Kim, B.D. Min, D.W. Yoo, H.J. Kim, A highly efficient PV system using a series connection of DC-DC converter