

DC LINK CAPACITOR BASED WIND AND SOLAR POWER GENERATION SYSTEM WITH VSC AND VSI METHOD

CHANDA JYOSTHNA¹, Y.VIJAY JAWAHAR PAUL²

¹PG Scholar, Department of EEE, *CHRISTU JYOTHI INSTITUTE OF TECHNOLOGY AND SCIENCE*, Warangal, Telangana, India.

²Assistant Professor, Department of EEE, *CHRISTU JYOTHI INSTITUTE OF TECHNOLOGY AND SCIENCE*, Warangal, Telangana, India.

ABSTRACT:

This project introduces a new topology, yet simple and efficient, for a grid-connected wind-solar cogeneration system. A permanent magnet synchronous generator-based full-scale wind turbine is interconnected to the utility-grid via back-to-back voltage-source converters (VSCs). The dc-link capacitor has been utilized to directly interface a photovoltaic solar generator. No dc/dc conversion stages are required, and hence, the hybrid system is simple and efficient. Moreover, the proposed topology features an independent maximum power point tracking for both the wind and the solar generators to maximize the extraction of the renewable energy. The regulation of the VSCs is achieved via the vector control in the rotating reference frame. The detailed small-signal models for the system components are developed to characterize the overall stability. The influence of the utility-grid faults on the performance of the proposed system is also investigated. Nonlinear time-domain simulation results under different operating conditions are presented to validate the effectiveness of the proposed topology.

Keywords: *VSC, VSI, PI controller, Power quality.*

1. INTRODUCTION:

The wind generator sector sustaining this power resource as a mainstream

renewable energy, with affordable prices in \$/ kWh when as compared to standard nonrenewable fuel source

nuclear power plant. This advancement is because of the development in electric generators and also power electronic devices. The major concern with renewable resource is that the power is not constantly readily available when it is required. With the boost of power manufacturing of renewable energies, energy combination has actually been created and also carried out as well as power digital inverters are utilized to regulate active/reactive power, regularity, and also to sustain grid voltage throughout mistakes and also voltage droops. Numerous control techniques have actually been presented in the literary works for wind generator in standalone as well as grid linked systems [5] The device side controllers are created to remove optimal power factor from wind utilizing hill-climbing control, fuzzy-based, and also flexible controllers [7], a lot of the moment based upon field-

oriented or vector control strategy. The grid side controllers are developed to make certain energetic as well as responsive power is provided to the grid In order to enable the academic structure, various power concepts have actually been suggested and also applied in electric power systems to evaluate present as well as voltage elements, such as the rapid power (PQ) concept for a three-phase system made by Akagi. In PQ concept, the three-phase is changed right into a two-phase referral structure in order to draw out energetic as well as responsive parts in a streamlined way. A three-phase power concept in a more comprehensive point of view has actually been presented, referred to as the conventional power concept (CPT), where the present and also voltage elements are obtained in the three-phase kind, without calling for any kind of reference-frame change.

The efficiency of these concepts has actually been contrasted.

This task suggests a control framework in three-phase 4 cord systems that give even more capability to the grid-side converter of a wind generator system making use of the CPT as a choice to creating various present referrals for discerning disruptions payment, where both solitary- and also three-phase lots are fed. Three-phase, four-wire inverters have actually been recognized making use of standard three-leg converters with "split capacitor" or four-leg converters. In a three-leg standard converter, the air conditioner neutral cable is straight linked to the electric omphalos of the dc bus. In four-leg converter, the air conditioning neutral cable link is offered with the 4th button leg. The "four-leg" converter geography has far better controllability compared to

the "split-capacitor" converter geography [7] The taken into consideration system includes solitary- as well as three-phase direct and also nonlinear (well balanced as well as out of balance) tons. The CPT is made use of to recognize as well as to evaluate the quantity of repellent, responsive, out of balance, and also nonlinear features of a certain tons under various supply voltages problem for four-wire system.

2. RELATED STUDY:

A solar photovoltaic (PV)-battery energy storage based microgrid with a multifunctional voltage source converter (VSC) is presented in this article. The maximum power extraction from a PV array, reactive power compensation, harmonics mitigation, balancing of grid currents and seamless transition from grid connected (GC) mode to standalone (SA) mode and vice versa, are

performed in this system. Whenever the grid fails, this system operates in SA mode automatically, thereby without causing any interruption in supplying the load. Similarly, it automatically shifts to the GC mode, when the grid is restored. The VSC functions in current control for GC mode, and it operates in voltage control for SA mode of operation. This system is capable of extracting the maximum power from the solar PV array irrespective it is operating in the GC mode or SA mode.

3. PROPOSED METHODOLOGY:

The proposed topology features an independent maximum power point tracking for both the wind and the solar generators to maximize the extraction of the renewable energy. The regulation of the VSCs is achieved via the vector control in the rotating reference frame. The detailed small-signal models for the system

components are developed to characterize the overall stability. The influence of the utility-grid faults on the performance of the proposed system is also investigated. Nonlinear time-domain simulation results under different operating conditions are presented to validate the effectiveness of the proposed topology.

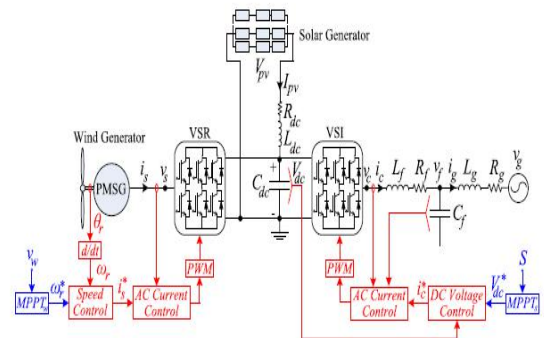

Fig.3.1. Block diagram.

4. SIMULATION RESULTS:

The hybrid wind-solar systems in highlights the efficient integration of the renewable energy resources with the minimal utilization of power electronic conversion stages. However, these systems are proposed for

specific off-grid applications. Up to the authors' best knowledge, the combination of the grid-connected wind-solar systems has been mainly addressed. The system in comprises a BtB VSCs to interface the solar and wind generators to the utility-grid. On the machine-side-VSC, the dc-link voltage is regulated to the maximum power-point tracking (MPPT) value of the PV panel by an outer loop Proportional-and-Integral (PI) dc voltage controller. The reference values of the machine-side currents are calculated using the synchronous detection method, and a hysteresis current controller is utilized for the regulation. On the grid-side- VSC, a hysteresis grid-current controller is used to inject the total currents to the utility-grid. In spite of the potential benefits of the proposed system in, the following challenges are noted;

- 1) The MPPT of either the PV and wind power involves the operation of both VSCs, which in some cases might decrease the system reliability and increase the losses. For instance, if the wind velocity is lower than the cut-off speed of the wind turbine, i.e., no wind power, the machine-side VSC may be unable to track the solar PV MPPT dc-link voltage.
- 2) The dc-link voltage is regulated from the machine-side, and there is no a direct regulation on the speed of the wind turbine, i.e., a servo operation.
- 3) The machine and grid-side currents are controlled using hysteresis controllers resulting in a variable switching frequency and higher harmonic contents.

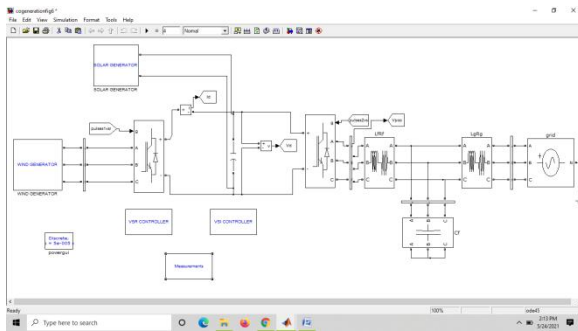

Fig.5.1. Proposed system model.

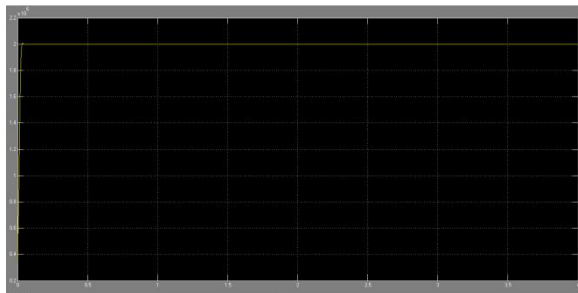

Fig.5.2. Wind power generation

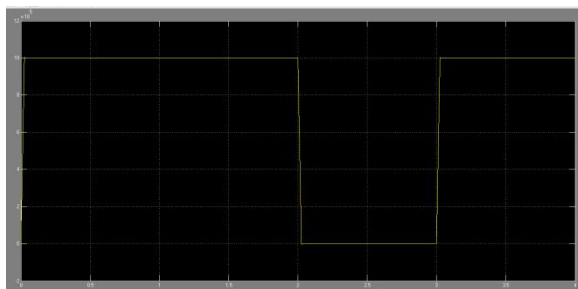

Fig.5.3. PV power at solar panel.

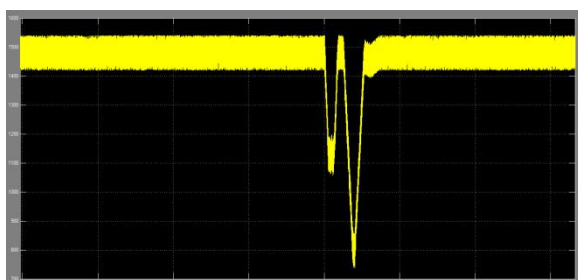

Fig.5.4. Fault applied indication time.

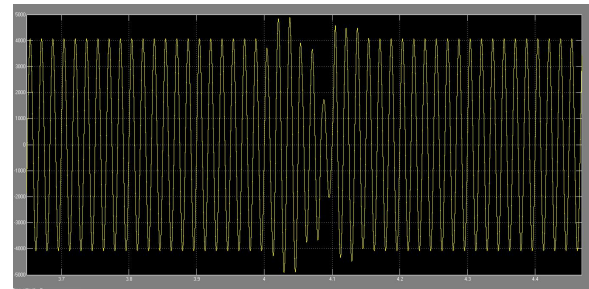

Fig.5.5. Fault applied at grid indication.

5. CONCLUSION:

This paper has presented the combination of the wind and solar systems using vector-controlled grid-connected B to B VSCs. The VSR at the wind generator side is responsible for extracting the maximum wind power following the wind velocity variations. On the utility-grid side, the roles of the VSI are to extract the maximum PV power from the PV generator, achieve the balance between the input and output powers across the dc-link capacitor, and to maintain a unity PCC voltage under different modes of operation. A small-signal linearization analysis has been

conducted where the entire state-space model is developed to investigate the system stability. The proposed system features the following advantages; 1) the increased reliability and efficiency due to the combined wind and solar generators. 2) the independent MPPT extraction as the VSR and VSI are solely responsible for extracting the wind and PV powers, respectively. 3) the regulation of the dc-link voltage under all operating conditions is maintained by the VSI and hence a better damped performance is yielded. 4) simple system structure and controllers design. 5) fault-ride through can be achieved using existing protection schemes. A well-damped performance and an efficient operation have been revealed from the time-domain simulations results under the Matlab/Simulink environment under different operational scenarios.

REFERENCES:

- [1] "Overall breeze report yearly market revive 2013," 2013. [Online]. Available: <http://www.gwec.net>
- [2] S. Li, T. A. Haskew, R. P. Swatloski, and W. Gathings, "Perfect and direct-current vector control of direct-decided PMSG wind turbines," *IEEE Trans. Power Electron.*, vol. 27, no. 5, pp. 2325– 2337, May 2012.
- [3] N. Angela, M. Liserre, R. A.Mastromauro, and A. D. Aquila, "An investigation of control issues in PMSG-based," *IEEE Trans. Ind. Informat.*, vol. 9, no. 3, pp. 1211– 1221, Aug. 2013.
- [4] J. Lagorse, M. G. Simões, and A. Miraoui, "A multiagent fleecy logicbased imperativeness organization of cross breed structures," *IEEE Trans. Ind. Appl.*, vol. 45, no. 6, pp. 2123– 2129, Nov./Dec. 2009.
- [5] X. Tan, Q. Li, and H. Wang, "Advances and examples of imperativeness accumulating

technology in microgrid," Int. J. Pick. Power Energy Syst., vol. 44, pp. 179–191, Jan. 2013.

[6] P. F. Ribeiro, B. K. Johnson, M. L. Crow, A. Arsoy, and Y. Liu, "Essentialness amassing structures for bleeding edge control applications," Proc. IEEE, vol. 89, no. 12, pp. 1744–1756, Dec. 2001.

[7] M.G. Simoes, B. K. Bose, and R. J. Spiegel, "Cushy method of reasoning based savvy control of a variable speed bind machine wind age structure," IEEE Trans. Power Electron., vol. 12, no. 1, pp. 87–95, Jan. 1997.

[8] A. Chauhan and R. P. Saini, "An overview on joined feasible power source system based power age for stay single applications: Configurations, storing decisions, estimating strategies and control," Renew. Support. Imperativeness Rev., vol. 38, pp. 99–120, Oct. 2014.

[9] C. N. Bhende, S. Mishra, and S. G. Malla, "Unending magnet synchronous generator-based autonomous breeze imperativeness supply system," IEEE Trans. Keep up. Essentialness, vol. 2, no. 4, pp. 361–373, Oct. 2011.